

## High Pressure, Subplate Mounted Directional Control Valves

**MODEL HP05**  
**5 gpm (19 L/min) nominal**  
**8000 psi (560 bar)**

Sliding-spool HP05 valves provide true four-way control in a simple compact package. They operate efficiently at pressures to 8000 psi (560 bar).

These valves are rated for 5 gpm (19 L/min) nominal flow. Flows to 25 gpm (95 L/min) are possible with some models (See "Typical Valve Performance", pages 3-4).

### RELIABLE, EFFICIENT OPERATION

HP05 valves feature smooth flow through the valve. Efficiency is enhanced with the use of a Dynex HP05 subplate, which takes advantage of this valve's special double tank port design.

Pressure drop is relatively low for a valve with this high pressure capability. This is achieved with large internal flow passages, with uniform flow areas throughout the body coring.

Typical loop pressure drop, at 15 gpm (57 L/min) flow, is 125 psi (8,6 bar) with Type 0 closed center spools; 120 psi (8,3 bar) with Type 1 open center spools. Refer to page 4 for pressure drop curves. Note that total "loop" drop ( $\Delta P_{loop}$ ) =  $P \rightarrow A + B \rightarrow T$ .

### SMOOTH, PRECISE SHIFTING

Spool travel is exceptionally smooth because of a four-land spool design. Additional outboard lands provide greater support than two-land designs.

Balancing grooves provide precise centering, reducing silt buildup. Close tolerances assure accurate land sequencing and low leakage.



HP05 Valve With Optional Plug-In-Terminal Solenoids

### RELIABLE VALVE SEALING

Tapered o-ring counterbores reduce leakage by assuring seal retention in rapid cycling operation. High-torque mounting prevents weepage.

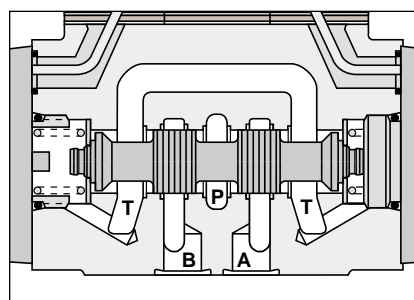

A second tank port into a common tank passageway provides low pressure drop. Efficiency is enhanced with the use of a Dynex HP05 subplate, which utilizes the valve's double tank port design.

### SOLENOID ADVANTAGES

Solenoid models are quiet and weather-tight for extra-long life. Wet armature design eliminates dynamic seals and increases the available shifting forces. Static o-rings prevent external leakage.

### MANUAL OVERRIDE

Solenoid override pins are made from corrosion-resistant brass for trouble-free operation. Convenient hand-actuated override, available as an option, provides solenoid override without the use of tools.

### PLUG-IN TERMINAL SOLENOIDS

Optional solenoid plugs simplify electrical connections during installation and servicing. These integral three-terminal, bi-polar plugs fit DIN Connector Standard 43650 (Hirschmann GDM 209).

# Valve Specifications and Application Data

## SPECIFICATIONS

### Special Mounting

Although similar to standard NFPA D05 (CETOP 5) valves in size, HP05 valves require a special mounting pattern. Refer to page 5.

### Rated Pressure

8000 psi (560 bar)

### Rated Flow

5 gpm (19 L/min) nominal; Maximum flow capacity depends on valve actuator, internal operator, spool type and other application factors. Flows to 25 gpm (95 L/min) are possible with some models (See "Typical Valve Performance", pages 3-4).

### Tank Port Pressure (Maximum)

Solenoid Actuated Models:

- Standard,
- 1000 psi (70 bar) dynamic,
- 3000 psi (210 bar) static;
- Explosion Proof (EPW),
- 1000 psi (70 bar) dynamic,
- 3000 psi (210 bar) static;
- High Pressure HPT Option
- 2000 psi (140 bar) dynamic,
- 3000 psi (210 bar) static;

Hydraulic and air actuated models:

- 3000 psi (210 bar)

### Response Time (Full Stroke)

Solenoid Energized:

- A.C., 10-20 ms; D.C., 25-35 ms

Spring Returned:

- A.C., 15-20 ms; D.C., 30-40 ms

### Wiring and Solenoid Options

- Standard Wiring Box with leads;
- Optional Terminal Strip, Cable Grip or Pin Connector (N.F.P.A. standard T3.5-29-1980; A.N.S.I. standard B93,55M-1981);
- Optional Plug-In-Terminal Solenoids fit DIN Connector Standard 43650 (Hirschmann GDM 209)

### Explosion Proof (EPW Option)

Solenoids with special enclosures are approved by UL and CSA for use in hazardous locations. Available A.C. only.

UL Classification:

- Class I, Group C, D;
- Class II, Group E, F, G

### CSA and UL Recognized (C Option)

Solenoid coils are printed with the symbol:



(CSA and UL Recognized)  
Available with 115/DF coils only. For other voltages, contact the Dynex sales department.

## HP05 VALVE ELECTRICAL DATA

Solenoid Code	Input Voltage (Volts)	Frequency (Hz)	Inrush Current (Amps)	Holding Current (Amps)	Holding Power (Watts)	Coil Resistance (Ohms ± 10%)
24/DF	24 A.C.	50	23.00	4.10	38	0.56
(Dual Frequency)	24 A.C.	60	21.00	3.15	38	0.56
115/DF	110 A.C.	50	4.80	0.88	37	10.20
(Dual Frequency)	115 A.C.	60	4.30	0.72	35	10.20
230/DF	220 A.C.	50	2.40	0.44	37	40.80
(Dual Frequency)	230 A.C.	60	2.20	0.36	35	40.80
460/DF	440 A.C.	50	1.30	0.23	37	188.50
(Dual Frequency)	460 A.C.	60	1.20	0.20	35	188.50
12VDC	12 D.C.	—	4.00	4.00	48	3.00
24VDC	24 D.C.	—	2.00	2.00	48	12.00
250VDC	250 D.C.	—	0.20	0.20	48	1300.00
12VDC EPW	12 D.C.	—	4.00	4.00	48	3.00
24VDC EPW	24 D.C.	—	2.00	2.00	48	12.00
110/50 EPW	110 A.C.	50	4.20	1.00	43	10.72
115/60 EPW	115 A.C.	60	3.90	8.90	43	10.47

## APPLICATION DATA

### Flow Actuating Pattern

Operating actuator "A" opens flow path to port "A" (P→A). Operating actuator "B" opens flow path to port "B" (P→B). Models with Code 6 operators are the exception. These are two position valves with a single solenoid which centers the spool when actuated.

Spring-centered or spring-offset models are spring positioned unless actuated continuously.

Valves with detented operation can be actuated momentarily (minimum electrical signal duration, 50 ms) to shift and hold the spool in that position.

### Mounting Position

Unrestricted for all models.

### Standard Seals

All valves use fluorocarbon (Viton® or Fluorel®) o-rings, providing greater fluid compatibility and improved temperature range performance.

### Fluid Recommendations

50 to 1500 SUS (7 to 323 cSt) viscosity; -20° to 200° F (-29° to 93° C) temperature range.

### Filtration

Five micron or better is recommended for this high pressure valve.

Fine filtration is especially critical for sliding spool valves held in one position for long periods, subjected to high system pressures. Silting may cause spool sticking and

improper shifting. To further prevent this occurrence, valves should be cycled periodically.

### Differential Cylinder Circuits

High differential flows in cylinder circuits can cause any hydraulic valve to malfunction.

Contact the Dynex sales department for a review of applications with differential flows (P→A versus B→T, or P→B versus A→T) above 5 gpm (19 L/min).

### Pressure Surges

Consistent with standard practice, the system should be protected from pressure surges. With a common tank line serving multiple valves, shifting of any spool valve can be affected by surges of oil.

A separate line to tank, or to another low pressure line, is recommended. This is particularly critical with detented models.

# Selecting Spools and Internal Operators

## SPOOL SELECTION

The table at right shows the most common spools. For applications requiring other spool configurations, contact the Dynex sales department.

Models with Code 1 or Code 2 internal operators use *Type 20* or *Type 21* spools. Models with other internal operators use *Type 0* or *Type 1* spools.

*Type 0* spools provide the same function as *Type 20* spools, and *Type 1* spools provide the same function as *Type 21* spools, but these spools are not physically interchangeable.

## INTERNAL OPERATORS

The table shows available internal operators. Flow symbols represent solenoid actuated models as reference. Flow pattern in the center position and during crossover is determined by the spool selected.

Code 3 operators (two position detented) hold the spool in the last actuated position.

With Code 4 and Code 6 operators, flow can be reversed with the "R" option. For example, with "R" in the model code, a Code 4 operator with a *Type 0* spool will direct flow to port "B" (P→B) in the actuated position.

## Typical Valve Performance

### SOLENOID MODELS

The curves at right show typical flow capacity for each spool type. The letters in the "Flow Curve Reference" table identify the appropriate curve.

For example, in the table under spool *Type 1*, curve "E" is called out for models with A.C. solenoids. Looking at the curves, "E" indicates a maximum capacity of 21 gpm (79,5 L/min) at pressures to 8000 psi (560 bar).

## INTERNAL OPERATORS

Operator Code	Actuator, Operation	Spool Types	Operator Function		
			Non-Actuated	Actuated	Function Symbol
1	Single Actuator, Two Position	20, 21	Offset P→B	P→A	
2	Single Actuator, Two Position	20, 21	Offset P→A	P→B	
3	Double Actuator, Two Position	0, 1	Detented in Actuated Positions	P→A or P→B	
4	Single Actuator, Two Position	0, 1, 3	Spring Centered	P→A	
5	Double Actuator, Three Position	All Types	Spring Centered	P→A or P→B	
6	Single Actuator, Two Position	0, 1, 3	Spring Offset P→B	Centered	

## FLOW CAPACITY — SOLENOID MODELS

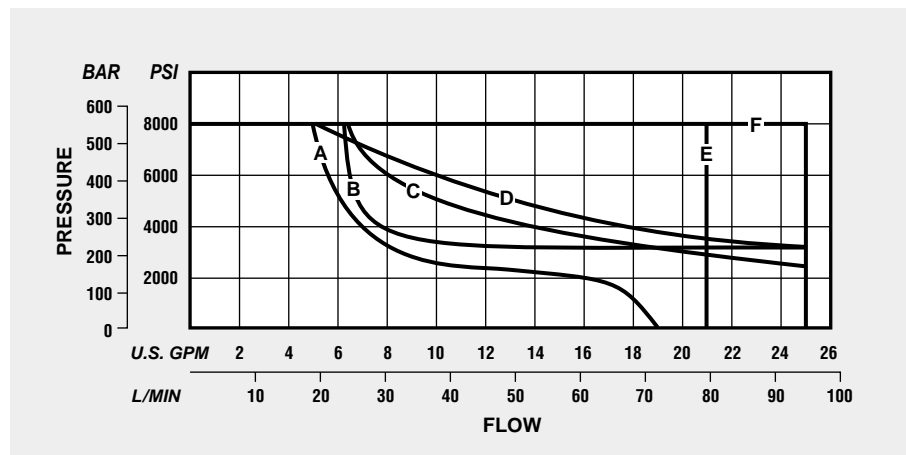

## FLOW CURVE REFERENCE

Solenoid Type	Spool Type					
	0	20	1	21	3	4
A.C.	F	A	E	B	D	F
D.C. & EPW	F	A	F	B	C	F

**PILOT OPERATED MODELS**

The maximum flow for pilot operated models is dependent on pilot pressure.

Generally, the maximum flow for most pilot operated valves is 10 gpm (38 L/min).

**Minimum Pilot Pressure**

Hydraulic, 500 psi (35 bar);  
Air, 75 psi (5 bar)

The value for hydraulic piloted models is based on zero tank pressure. As back pressure increases above zero, the minimum pilot pressure must be increased equally.

**Maximum Pilot Pressure**

Hydraulic, 3000 psi (210 bar);  
Air, 200 psi (14 bar)

**Volume**

Maximum required to shift spool full stroke:  
Hydraulic, 0.014 in<sup>3</sup> (0,23 cm<sup>3</sup>);  
Air, 0.220 in<sup>3</sup> (3,61 cm<sup>3</sup>)

**Determining Valve Efficiency**

**PRESSURE DROP**

These curves show resistance to flow for specific flow paths and various spool types. The “Flow Curve Reference” table identifies the proper curve.

Maximum flow capacity depends on valve actuator, internal operator, spool type and other application factors. For maximum flow capacity refer to the curves on page 3.

**AN EXAMPLE**

In the table under spool Type 1, curve “C” is called out to determine the pressure drop for P→A. Looking at the curves, “C” indicates a drop of about 75 psi at 15 gpm (4,8 bar at 57 L/min).

To determine total “loop” drop, the individual pressure drops for P→A and B→T (or P→B and A→T) must be added.

**PRESSURE DROP (ΔP)**

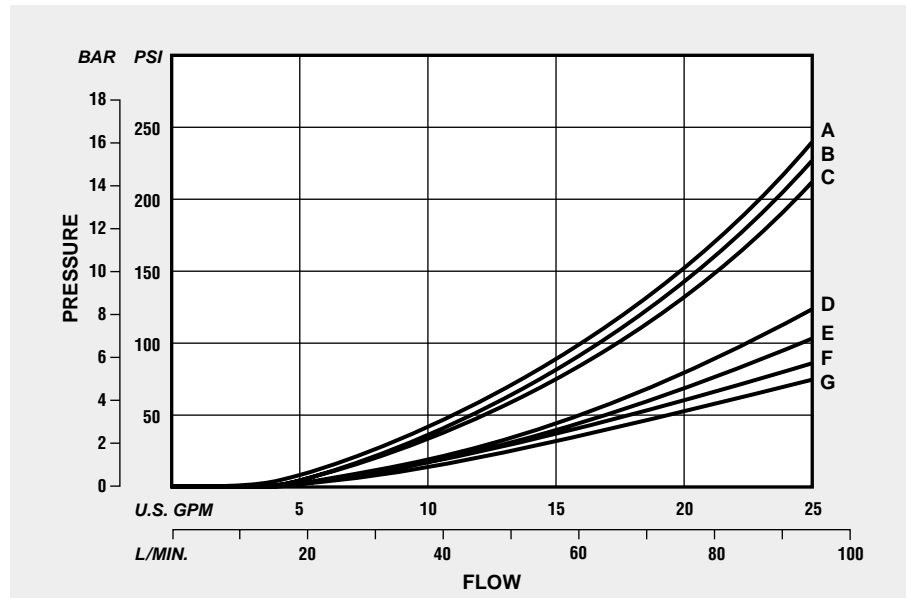

① These curves indicate efficiency for various spool types. For maximum flow capacity refer to the curves on page 3.

**FLOW CURVE REFERENCE**

Flow Path	Spool Type					
	0	20	1	21	3	4
P→A	B	B	C	C	A	C
P→B	B	B	C	C	A	C
A→T	D	D	G	D	F	E
B→T	D	D	G	D	F	E
P→T	—	—	B	—	—	—

# Installation and Dimensions

## SPECIAL VALVE MOUNTING

The mounting surface drawing shows the minimum flush or raised surface required for this special pattern.

Mounting face must be flat within 0.0004 inch/4.0 inches (0,010 mm/102 mm) with a surface finish of 32 microinch (0,80 µm) AA.

Port o-rings are included with all valves. Mounting bolts must be ordered separately; 0.3125-18 U.N.C. Threaded x 1.00 inch (24,5 mm), Grade 8 or better; four required. Recommended mounting torque is 25 lb·ft (34 N·m) maximum.

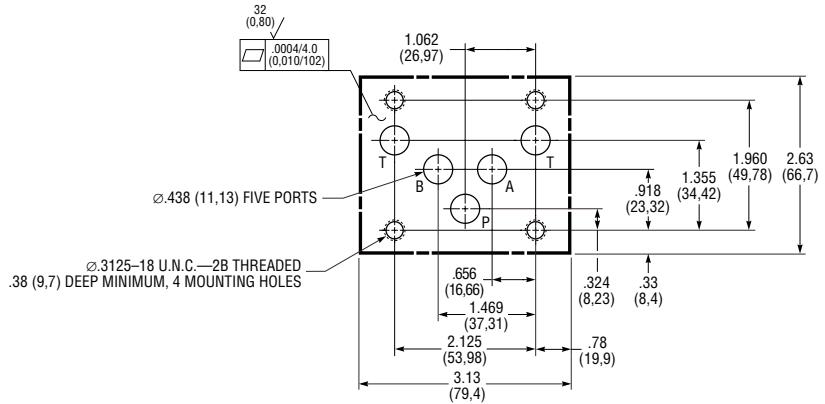

Minimum Mounting Surface, Special HP05 Pattern

## SUBPLATE AND BOLT KITS

Subplates are available for mounting HP05 pattern valves, with a choice of S.A.E. or British Standard Pipe (B.S.P.) ports, or ports which fit Autoclave or Butech fittings.

Mounting bolts are supplied with kit. When ordering together, valves are not mounted on subplates.

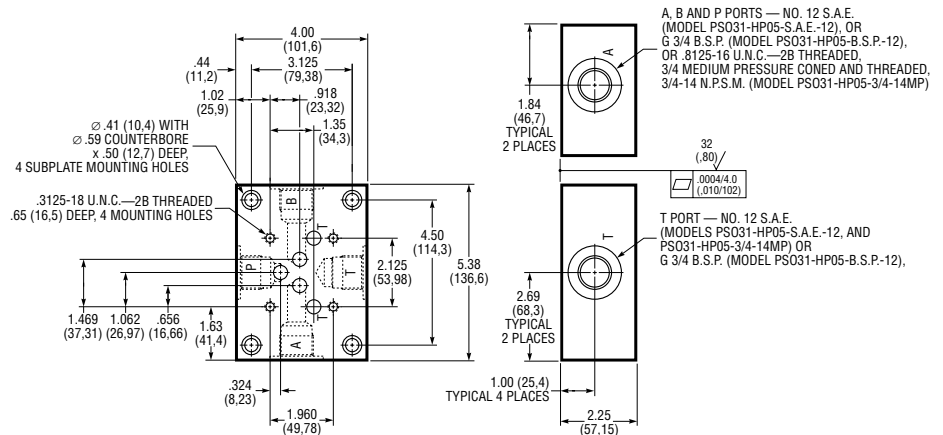

Subplate PSO31-SAE-12 or PSO31-BSP-12 or PSO31-3/4-14MP

## KIT PART NUMBERS

Item (Part Number)	Description
Subplate (PSO31-SAE-12)	Side Ports, S.A.E. No. 12
Subplate (PSO31-BSP-12)	Side Ports, G 3/4 (B.S.P.) <sup>①</sup>
Subplate (PSO31-3/4-14MP)	Side Ports, 3/4-14 N.P.S.M. Medium Pressure Coned and Threaded <sup>②</sup>
Bolt Kit (P31-BK-16)	(4) 0.3125-18 U.N.C. Threaded x 1.00 Inch (25,4 mm)
Spacer Kit (10921320)	For mounting EPW models on PSO subplate or manifold.
Bolt Kit (P31-BK-32)	For use with above spacer: (4) 0.3125-18 U.N.C. Threaded x 2.00 Inches (50,8 mm)

① Port fits British Standard Pipe fitting.

② High pressure port fits Autoclave Medium Pressure, Butech M/P or equivalent fitting.

## SOLENOID MODEL DIMENSIONS

Dimensions are shown, at right, for both A.C. and D.C. solenoids; D.C. configuration shown printed in gray.

Overall length of single solenoid configuration (not shown) is 7.67 inches (194,8 mm), A.C.; and 9.02 inches (229,1 mm), D.C.

### Weight (Mass)

Single Solenoid:

- A.C., 8.1 lb (3,7 kg);
- D.C., 9.5 lb (4,3 kg)

Double Solenoid:

- A.C., 9.6 lb (4,4 kg);
- D.C., 12.6 lb (5,7 kg)

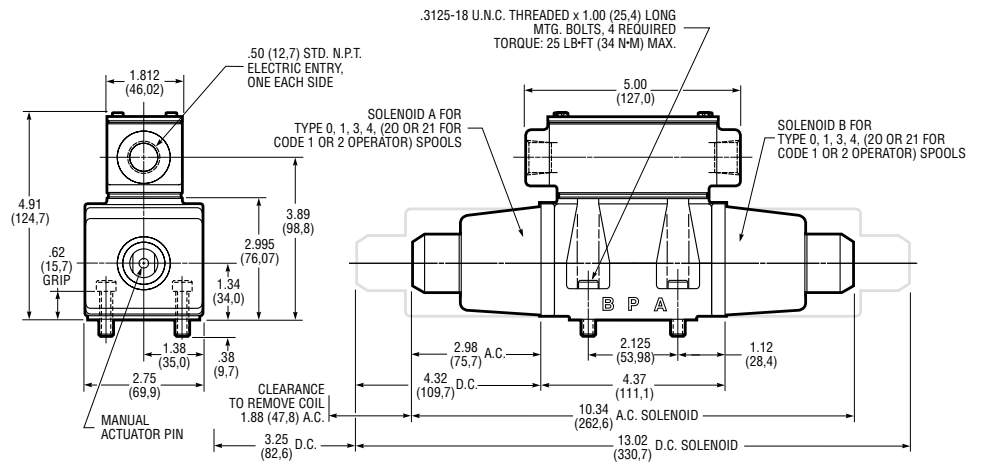

6500 Series, Double Solenoid Models

## EXPLOSION PROOF SOLENOIDS

Solenoids with special enclosures are approved by *UL* and *CSA* for use in hazardous locations (available A.C. only). Overall length of single solenoid model (not shown) is 9.31 inches (236,5 mm).

Note that spacer plate (No. 10921320) is required when valves are mounted on manifolds, side outlet subplates or when used as a pilot valve.

### Weight (Mass)

- Single Solenoid: 15.7 lb (7,1 kg);
- Double Solenoid: 24.8 lb (11,2 kg)

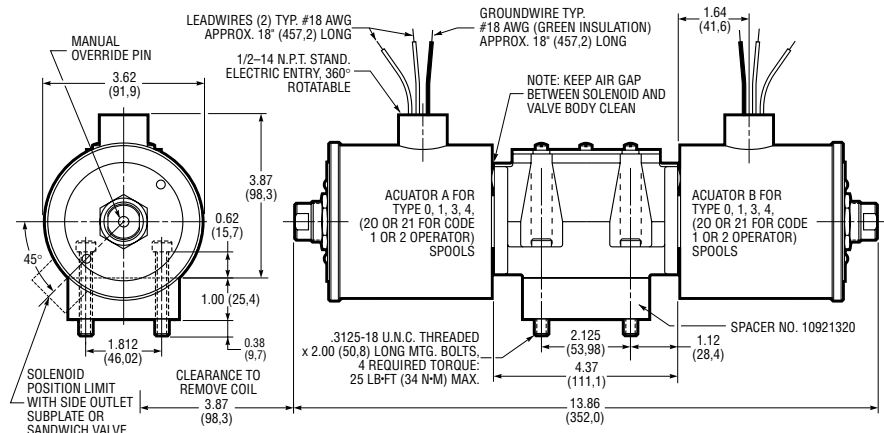

6500 Series, Double EPW Solenoid Models

## HYDRAULIC PILOTED MODELS

Single and double actuator models are available. Overall length of single actuator configuration (not shown) is 6.60 inches (167,6 mm).

Refer to page 4 for required shifting pressure and volume.

### Weight (Mass)

Single Actuator: 7.1 lb (3,2 kg);

Double Actuator: 7.8 lb (3,5 kg)

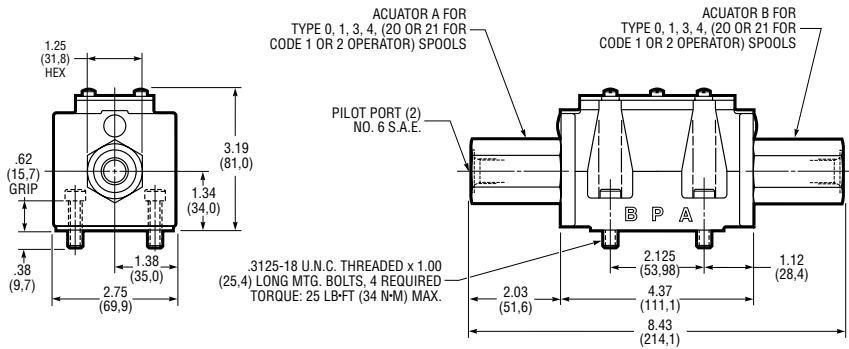

6800 Series, Double Hydraulic Piloted Models

## AIR PILOTED MODELS

Single and double actuator models are available. Overall length of single actuator configuration (not shown) is 7.13 inches (118,1 mm).

Refer to page 4 for required shifting pressure and volume.

### Weight (Mass)

Single Actuator: 8.0 lb (3,6 kg);

Double Actuator: 9.5 lb (4,3 kg)

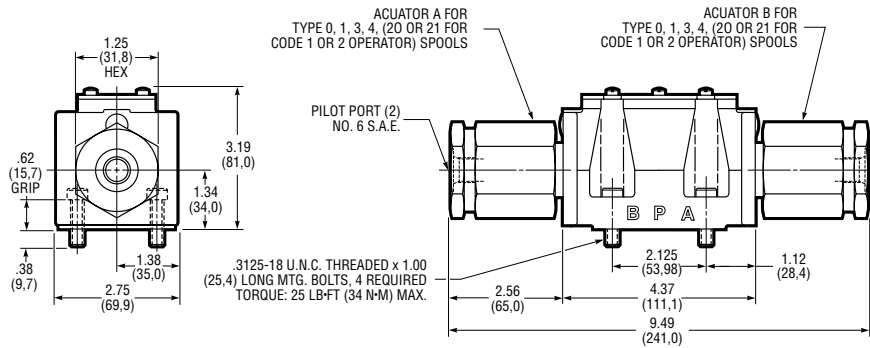

6900 Series, Double Air Piloted Models

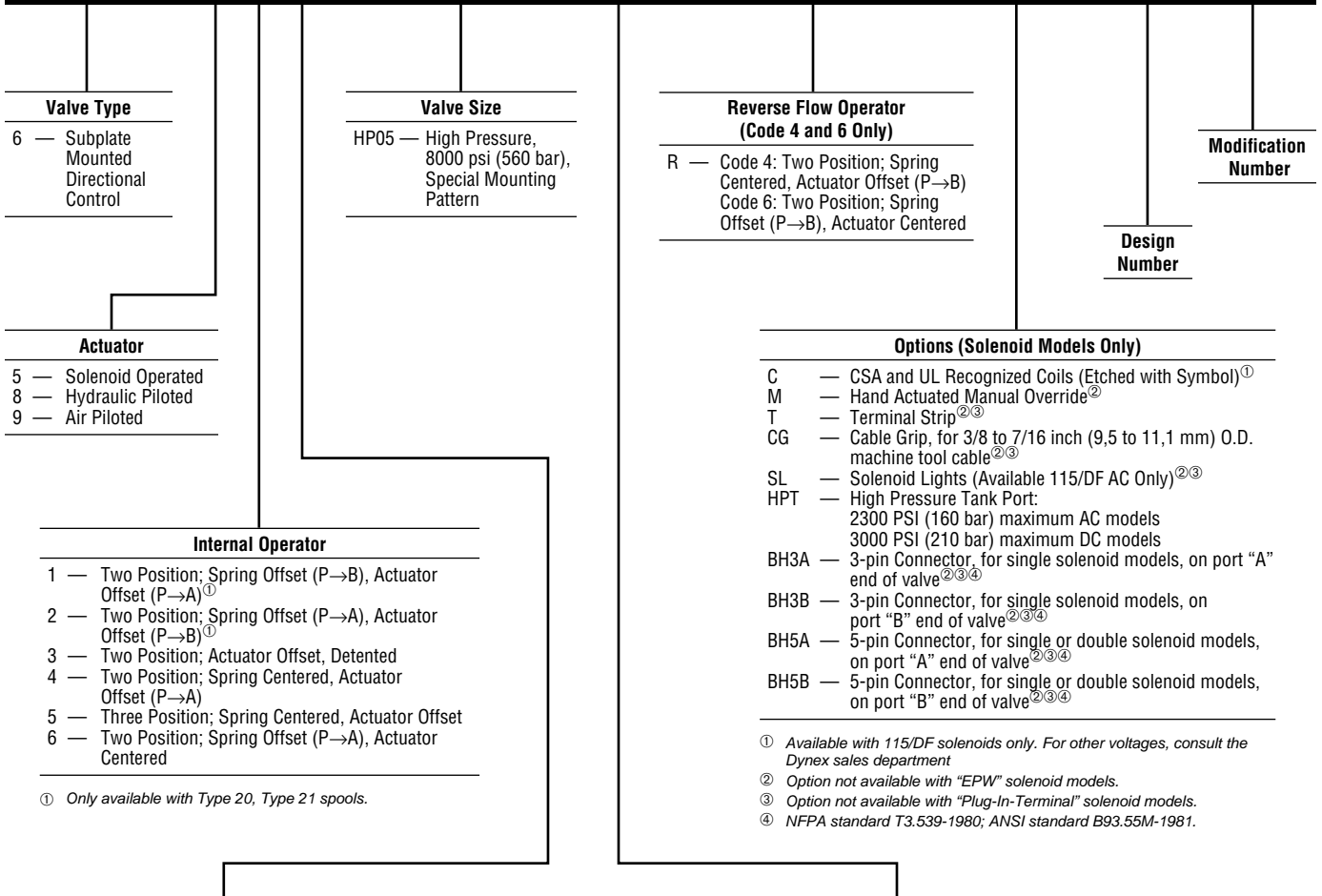

**Valve Type**  
 6 — Subplate Mounted Directional Control

**Valve Size**  
 HP05 — High Pressure, 8000 psi (560 bar), Special Mounting Pattern

**Reverse Flow Operator (Code 4 and 6 Only)**  
 R — Code 4: Two Position; Spring Centered, Actuator Offset (P→B)  
 Code 6: Two Position; Spring Offset (P→B), Actuator Centered

**Modification Number**

**Design Number**

**Actuator**  
 5 — Solenoid Operated  
 8 — Hydraulic Piloted  
 9 — Air Piloted

**Options (Solenoid Models Only)**

- C — CSA and UL Recognized Coils (Etched with Symbol)<sup>①</sup>
- M — Hand Actuated Manual Override<sup>②</sup>
- T — Terminal Strip<sup>②③</sup>
- CG — Cable Grip, for 3/8 to 7/16 inch (9,5 to 11,1 mm) O.D. machine tool cable<sup>②③</sup>
- SL — Solenoid Lights (Available 115/DF AC Only)<sup>②③</sup>
- HPT — High Pressure Tank Port:  
 2300 PSI (160 bar) maximum AC models  
 3000 PSI (210 bar) maximum DC models
- BH3A — 3-pin Connector, for single solenoid models, on port "A" end of valve<sup>②③④</sup>
- BH3B — 3-pin Connector, for single solenoid models, on port "B" end of valve<sup>②③④</sup>
- BH5A — 5-pin Connector, for single or double solenoid models, on port "A" end of valve<sup>②③④</sup>
- BH5B — 5-pin Connector, for single or double solenoid models, on port "B" end of valve<sup>②③④</sup>

- Internal Operator**
- 1 — Two Position; Spring Offset (P→B), Actuator Offset (P→A)<sup>①</sup>
  - 2 — Two Position; Spring Offset (P→A), Actuator Offset (P→B)<sup>①</sup>
  - 3 — Two Position; Actuator Offset, Detented
  - 4 — Two Position; Spring Centered, Actuator Offset (P→A)
  - 5 — Three Position; Spring Centered, Actuator Offset
  - 6 — Two Position; Spring Offset (P→A), Actuator Centered

① Only available with Type 20, Type 21 spools.

① Available with 115/DF solenoids only. For other voltages, consult the Dynex sales department  
 ② Option not available with "EPW" solenoid models.  
 ③ Option not available with "Plug-In-Terminal" solenoid models.  
 ④ NFPA standard T3.539-1980; ANSI standard B93.55M-1981.

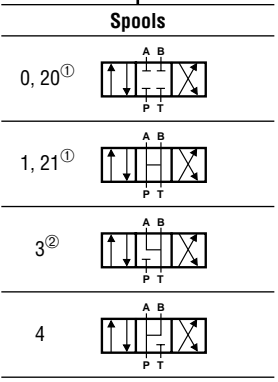

① Code 1 or Code 2 operators use Type 20 or Type 21 spools. These spools provide the same function, but are not interchangeable with Type 0 or 1 spools.  
 ② Closed crossover

**Electrical – Solenoid Options**

<b>STANDARD SOLENOIDS:</b>		<b>PLUG-IN TERMINAL SOLENOIDS:<sup>①</sup></b>
24/DF	— Dual Frequency, 24/60, 24/50	115/HAC — Dual Frequency, 115/60, 110/50
115/DF	— Dual Frequency, 115/60, 110/50	230/HAC — Dual Frequency, 230/60, 220/50
230/DF	— Dual Frequency, 230/60, 220/50	12/HDC — Direct Current, 12 Volts
460/DF	— Dual Frequency, 460/60, 440/50	24/HDC — Direct Current, 24 Volts
12VDC	— Direct Current, 12 Volts	
24VDC	— Direct Current, 24 Volts	
250 VDC	— Direct Current, 250 Volts	
12VDC EPW	— Explosion Proof Solenoids	
24VDC EPW	— Explosion Proof Solenoids	
110/50 EPW	— Explosion Proof Solenoids	
115/60 EPW	— Explosion Proof Solenoids	

For Other Voltages, Consult the Dynex Sales Department

① Fits DIN Connector Standard 43650 (Hirschmann GDM 209)